

## K430/K430S

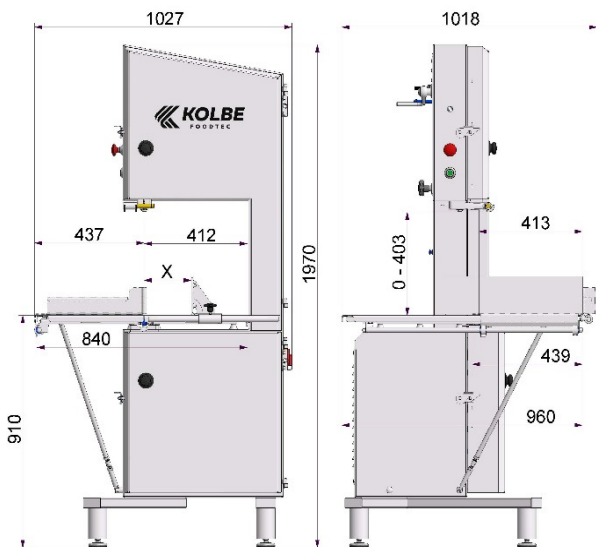

S-TISCH

Bandsäge	Bandsaw	K430(S)	
<b>Raddurchmesser</b>	Wheel diameter	mm	430
<b>Bandsägeblatt</b>	Bandsaw blade	mm	3370x16
<b>Bandgeschwindigkeit</b>	Blade speed	m/s	32
<b>Schnitthöhendurchlass</b>	Pass of cutting height	mm	max. 403
<b>Schnittseitendurchlass</b>	Pass of cutting side	mm	max. 412
<b>Schnitthub</b>	Cutting stroke	mm	max. 413
<b>Antriebsmotor</b>	Drive motor	kW	2,9 (4,0)



Technische Änderungen vorbehalten - Specifications subject to change without notice

## K430RT



Bandsäge	Bandsaw	K430RT	
<b>Raddurchmesser</b>	Wheel diameter	mm	430
<b>Bandsägeblatt</b>	Bandsaw blade	mm	3370x16
<b>Bandgeschwindigkeit</b>	Blade speed	m/s	32
<b>Schnitthöhendurchlass</b>	Pass of cutting height	mm	max. 367
<b>Schnittseitendurchlass</b>	Pass of cutting side	mm	max. 405
<b>Schnitthub</b>	Cutting stroke	mm	mm. 409
<b>Antriebsmotor</b>	Drive motor	mm	2,9 (4,0)

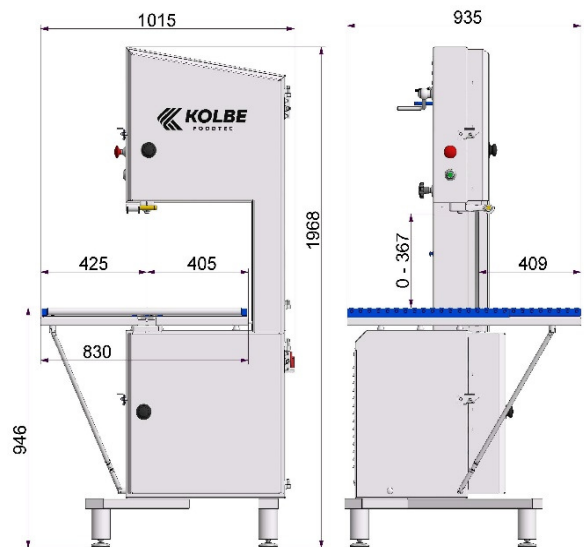

Technische Änderungen vorbehalten - Specifications subject to change without notice